

ART.3083

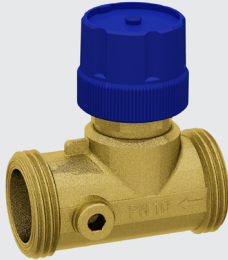

1" M shut-off valve suitable for thermo-electric actuator complete with plug for probe seating.

ART.3087

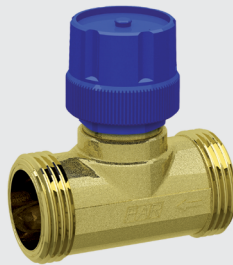

1" M shut-off valve suitable for thermo-electric actuator.

ART.3088

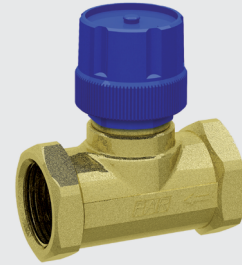

3/4" F shut-off valve suitable for thermo-electric actuator.

1 DESCRIPTION

The shut-off valves **Art.3083-3087-3088** are designed to shut-off the fluid in heating, cooling and domestic systems. To control shutter opening and closing FAR offers its range of thermo-electric actuators, to choose according to the systems requirements.

The valve sides (Art.3083) have plugs for the installation of the seating for the temperature probe.

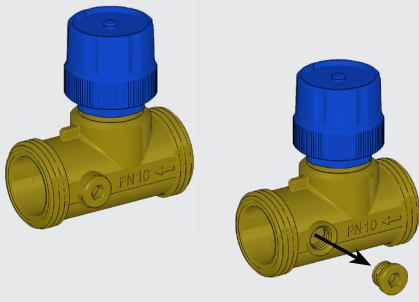

Construction materials

Regulating handle and ring: ABS

Pin: AISI 303 stainless steel

Sealing O-ring: EPDM

Valve body: CW617N brass

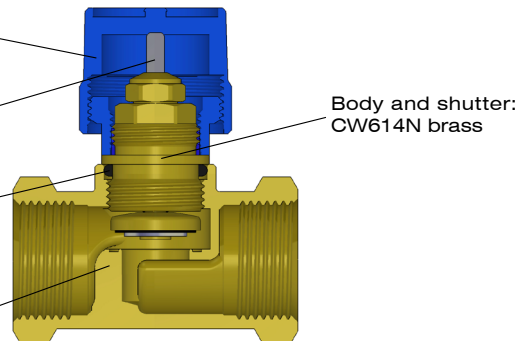

2 INSTALLATION

To install the actuator on the valve, remove the handle and screw the ring directly onto the blue threaded adapter. Hand-tighten the actuator and the ring. Do not use plumbing wrenches, tongs or similar tools. Take care to install the wire in such a way that it doesn't come into direct contact with pipes, radiators, etc.

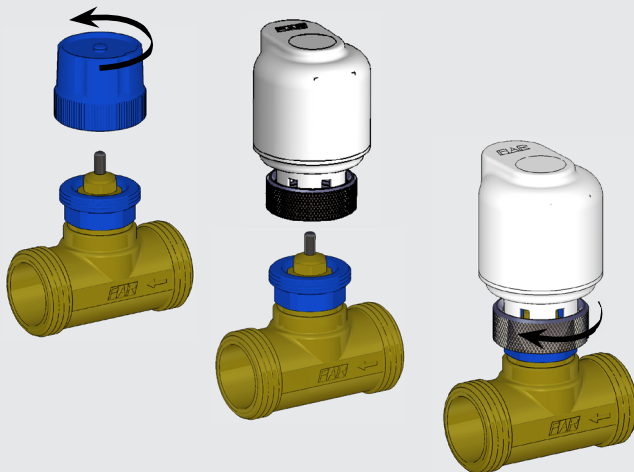

2 WIRING THERMO-ELECTRIC ACTUATOR



Code	Voltage	Type	Open. time
1909	24V	N.C.	180s
1919	230V	N.C.	180s
1929	24V	N.A.	180s
1939	230V	N.A.	180s

*NC: normalmente chiuso
*NA: normalmente aperto

4 WIRING THERMO-ELECTRIC ACTUATOR WITH AUXILIARY MICRO-SWITCH



Code	Voltage	Type	Open. time
1913	24V	N.C.	90s
1914	24V	N.C.	180s
1923	230V	N.C.	90s
1924	230V	N.C.	180s

3 FLUID DYNAMICS FEATURES

Art.3083

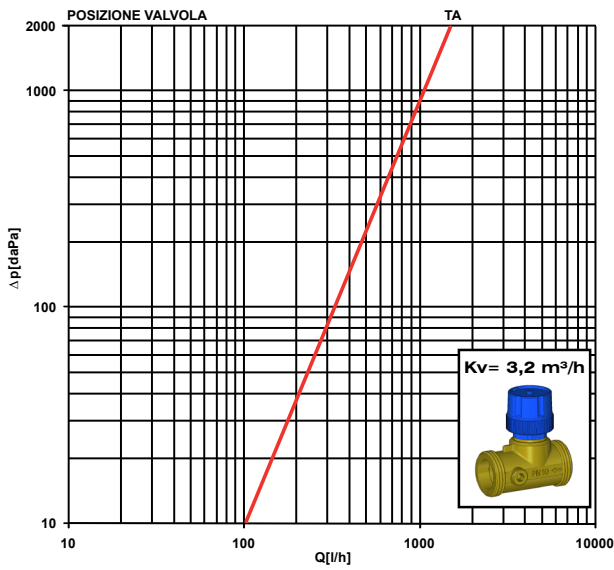

Art.3087-3088

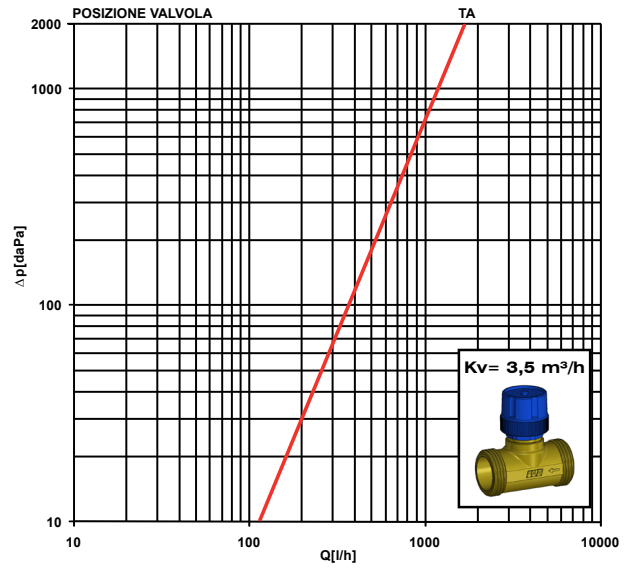

4 TECHNICAL FEATURES

Max. temperature: 95°C
 Max. pressure : 10 bar
 Max. differential pressure: 3 bar
 Valve body: CW617N brass
 Body: CW614N brass
 Ring and handle: ABS

5 DIMENSIONAL FEATURES

